

FLEXIBLE COUPLING DETAILS

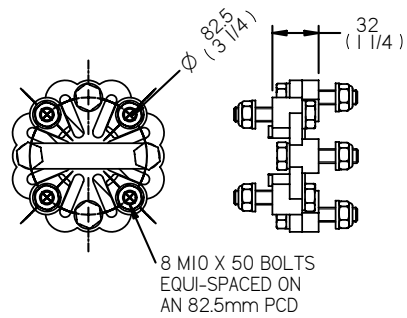

FLEXIBLE MOUNT DETAILS

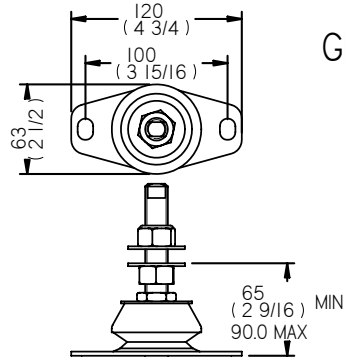

GEARBOX OUTPUT

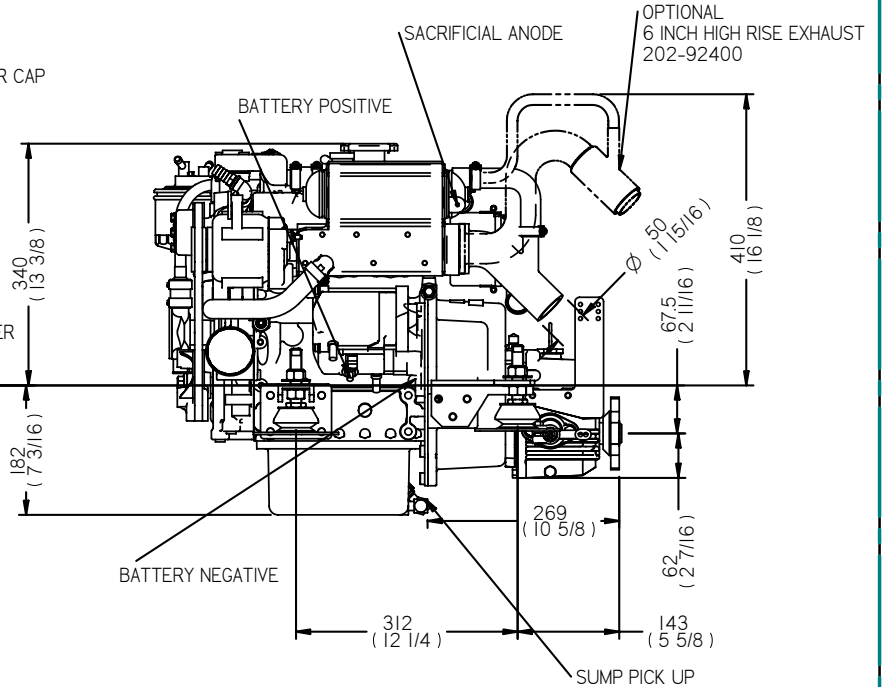
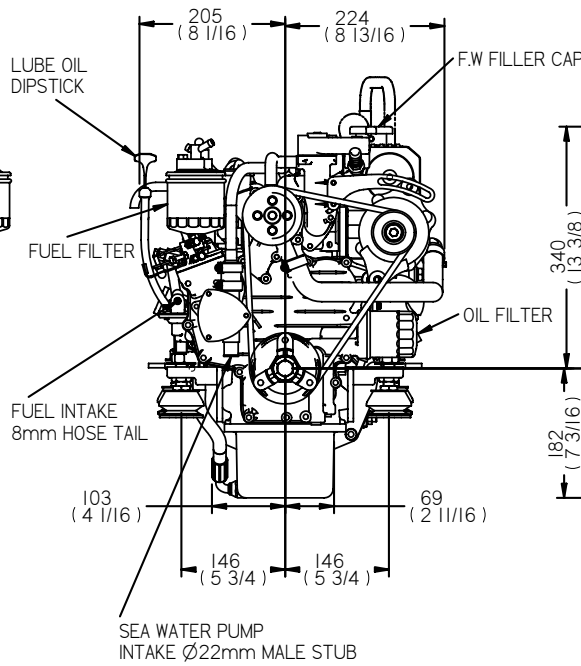
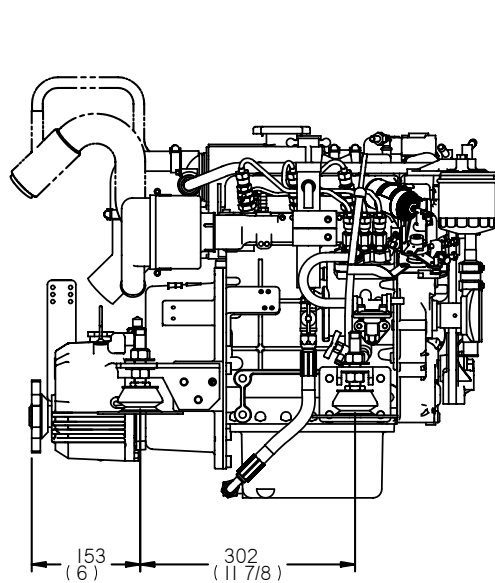
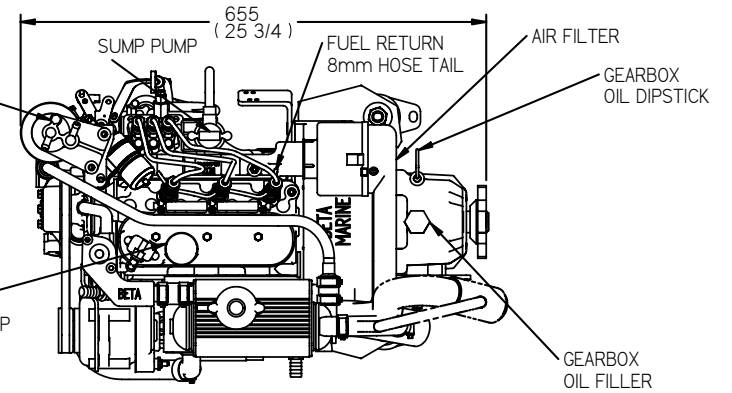
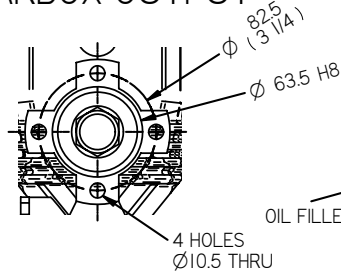

REV	DESCRIPTION	DATE	APP'D	DRAWN
01	FUEL FILTER, H/E TANK AND AIR FILTER	01/10/01	LT	TW
02	CALORIFIERS AND TIER2 CLOSED BREATHER	27/03/07	LT	TW

NOTES Measurements are in: mm (Inch to the closest 1/16)

TITLE **BD722 HEAT EXCHANGE TMC40  
ATOMIC FEET**

DIMENSIONS IN MM (INCH)  
DO NOT SCALE

BETA MARINE

TEL: (01452) 723492 FAX: (01452) 729916

MATL:  
BETA MARINE LTD,  
DAVY WAY,  
WATERWELLS,  
QUEDGELEY,  
GLOUCESTER, GL2 2AD, UK

DRAWN BY:- TW	SIZE A4	DWG NO. 100-05057	REV 02
CHECKED BY:- LT	SCALE NTS	PAGE 1 of 1	DATE 27/03/2007